

## MATHEMATICS CURRICULA IN SCHOOLS

Kho Tek Hong

Curriculum Development Institute of Singapore

Formal education in Singapore includes Pre-Primary, Primary, Secondary and Pre-University education.

### Pre-Primary Education

Nowadays, more and more children attend Pre-Primary classes before their actual Primary School education, although Pre-Primary education is not a requirement for admission to Primary One. According to a survey made by the Ministry of Education, nearly 90% of Primary One pupils in 1980 have attended Pre-Primary classes. The pupils are able to count from 1 to 20 and do simple matching and sorting exercises before attending Primary One.

### Primary School Education

Under the New Education System (Primary Level) which was implemented in January 1980, Primary school education lasts six to eight years. Mathematics is a compulsory subject. The pupils follow a common course in Primary One (P1) to Primary Three (P3). There are four language streams : English, Chinese, Malay and Tamil. Mathematics is taught in English in all language streams.

In Primary Four, the pupils are streamed to the Normal Bilingual, Extended Bilingual and Monolingual Courses according to their abilities and achievement. The content of the mathematics syllabus for the Extended Bilingual Course (P4E to P8E) is exactly the same as that for the Normal Bilingual Course (P4N to P6N), except that the latter is stretched over two extra years. The pupils will sit the same paper in the Primary School Leaving Examination (PSLE) at the end of P6N/P8E. The language of instruction for mathematics is English. The mathematics syllabus for the Monolingual Course (P4M to P8M) aims at basic numeracy, and the language of instruction for mathematics may be English or Chinese depending on the language stream of the course. The pupils will be directed to vocational training after P8M. As such, P8M is the terminal point of their formal education. Provisions have been made for lateral movements between the Normal Bilingual, Extended Bilingual and Monolingual Courses. Such movements are indicated by the dotted lines in the flow-chart shown below:

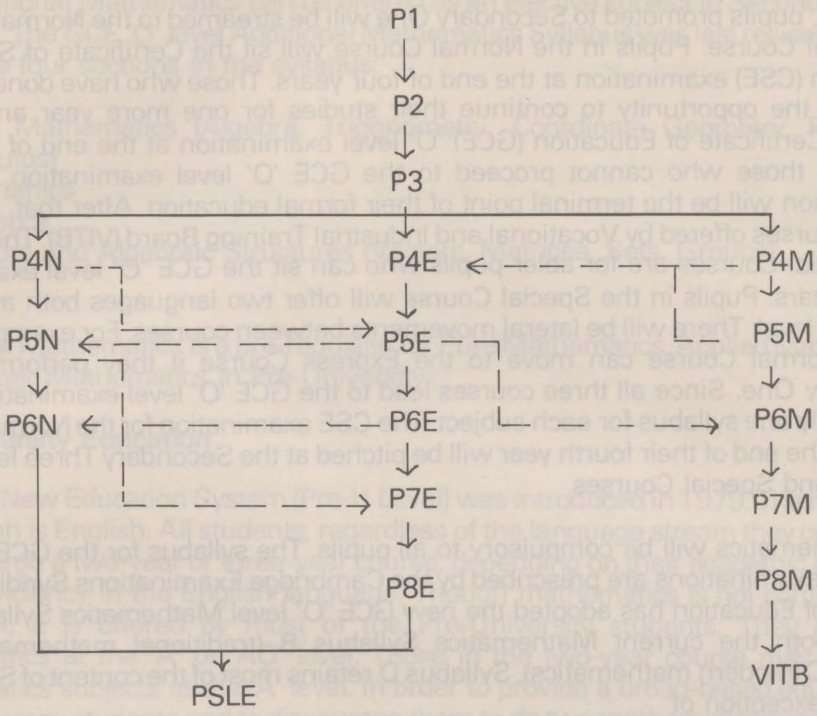

The Revised Mathematics Syllabus for the New Education System (Primary Level) has been scheduled for implementation as follows:

1980	1981	1982	1983	1984	1985
P1	P2	P3	P4N	P5N	P6N
		P4E	P5E	P6E	P8E
		P6M		P7E	
P4M	P5M	P6M	P7M	P8M	

According to the schedule, the Primary Three streaming examination in 1982 and the Primary School Leaving Examination (PSLE) in 1985 will be based on the new syllabus. The content of the syllabus remains essentially traditional. The main objective is to enable the pupils to acquire the basic mathematical skills and use them to observe, estimate, collect data, classify, measure, and solve problems. Introductory geometry and algebra are taught in the Normal Bilingual and Extended Bilingual Courses but not in the Monolingual Course.

**Secondary School Education**

The New Education System (Secondary Level) has been scheduled for implement-

ation level by level, commencing with Secondary One in 1981. Based on the results of the PSLE, pupils promoted to Secondary One will be streamed to the Normal, Express or Special Course. Pupils in the Normal Course will sit the Certificate of Secondary Education (CSE) examination at the end of four years. Those who have done well will be given the opportunity to continue their studies for one more year and sit the General Certificate of Education (GCE) 'O' level examination at the end of their fifth year. For those who cannot proceed to the GCE 'O' level examination, the CSE examination will be the terminal point of their formal education. After that, they may attend courses offered by Vocational and Industrial Training Board (VITB). The Express and Special Courses are for abler pupils who can sit the GCE 'O' level examination in four years. Pupils in the Special Course will offer two languages both at the first language level. There will be lateral movements between courses. For example, pupils in the Normal Course can move to the Express Course if they perform well at Secondary One. Since all three courses lead to the GCE 'O' level examination, there will be only one syllabus for each subject. The CSE examination for the Normal Course pupils at the end of their fourth year will be pitched at the Secondary Three level of the Express and Special Courses.

Mathematics will be compulsory to all pupils. The syllabus for the GCE 'O' level and CSE examinations are prescribed by the Cambridge Examinations Syndicate. The Ministry of Education has adopted the new GCE 'O' level Mathematics Syllabus D to replace both the current Mathematics Syllabus B (traditional mathematics) and Syllabus C (modern mathematics). Syllabus D retains most of the content of Syllabus C with the exception of

- i) algebra of inequalities
- ii) graphs of the sine and cosine functions
- iii) number bases
- iv) plans and elevations
- v) drift, heading (course) and track.

A greater emphasis has been placed on the basic skills of arithmetic and algebra. Syllabus D will be examined in Singapore for the first time in 1982. With the introduction of Syllabus D, candidates will be allowed to use calculators in the GCE 'O' level and the CSE examinations. They will, however, be prohibited to use mathematical tables, slide rule and calculators in the first paper. This will ensure that pupils master the basic skills.

The Revised Mathematics Syllabus for the New Education System (Secondary Level) is based on the GCE 'O' level Mathematics Syllabus D. It has been scheduled for implementation, level by level, commencing with Secondary One in 1981. The Special and Express Courses will follow the same syllabus. The content of the mathematics syllabus for the Normal Course in the first four years leading to the CSE examination (S1N to S4N) will be the same as that for the first three years of the Special Course (S1S to S3S) and the Express Course (S1E to S3E). The mathematics syllabus for the CSE examination is a subset of the GCE 'O' level Mathematics Syllabus D. It consists only the traditional mathematics topics and statistics. The modern topics of Syllabus D (sets, probability, linear programming, vectors, matrices and transformations) will be taught in the last year of the three courses (S4S, S4E and S5N). The GCE 'O' level Mathematics Syllabuses B and C will be phased out in schools after 1983.

Additional Mathematics can be offered as an elective subject in Secondary Three and Four. The GCE 'O' level Additional Mathematics Syllabus was last revised in 1974. There are four sections in the syllabus:

- a) Pure Mathematics (Algebra, Trigonometry, Coordinate Geometry, Functions, Calculus)
- b) Mechanics
- c) Statistics
- d) Vectors and Algebraic Structures (Vectors, Matrices, Sets, Groups)

Additional Mathematics is a pre-requisite for Pure Mathematics, Applied Mathematics and Further Mathematics in Pre-University.

### Pre-University Education

The New Education System (Pre-U Level) was introduced in 1979. The medium of instruction is English. All students, regardless of the language stream they come from, will undergo a two-year or three-year course, depending on their academic ability and their proficiency in the English language. Though mathematics is not compulsory at this level, it is offered by most of the Pre-University students. They may offer mathematics at the 'A' or 'AO' level. Those in the two-year course may offer two mathematics subjects at the 'A' level. In order to provide a broad-based education for Pre-University students and to discourage them to do two mathematics subjects at the 'A' level unless they are capable, the Ministry of Education has set a pre-requisite of grades 1 to 3 in both the GCE 'O' level Mathematics and Additional Mathematics. The syllabus for mathematics at the 'AO' level is the same as the GCE 'O' level Additional Mathematics syllabus. It is offered to those students who do not have a good foundation of mathematics and who wish to read Business Administration, Accountancy, etc. in the University. These subjects require mathematics as a pre-requisite, at least at the 'AO' level.

Six mathematics subjects are being offered at the 'A' level. They are Mathematics (Syllabus A), Mathematics (Syllabus B), Pure Mathematics, Applied Mathematics, Statistics and Further Mathematics. A student can offer either Mathematics (Syllabus A) or Mathematics (Syllabus B) as a single mathematics subject at the 'A' level. If he offers two mathematics subjects at the 'A' level, the following combinations may be considered.

- a) Pure Mathematics and Applied Mathematics.\*
- b) Pure Mathematics and Statistics
- c) Mathematics (Syllabus B) and Further Mathematics.

(\* Applied Mathematics consists of Mechanics problems only).

Mathematics (Syllabus A) includes Pure Mathematics (Algebra, Trigonometry, Coordinate Geometry, Calculus), Mechanics and Statistics. There are two papers in the examination. Mechanics and Statistics problems are set in Paper Two only. Candidates may attempt one paper or both.

Mathematics (Syllabus B) was introduced in 1972 and revised in 1978. There are two papers in the examination. Each paper is divided into two sections. Section A covers the following topics:

Algebra,	Probability
Trigonometry,	Analysis
Vectors *,	Matrices and Transformations *
Complex Numbers *,	Relations and Functions *

(\*These topics are not found in Syllabus A)

Section B comprises five options.

Option a	Particle Mechanics
Option b	Probability and Statistics
Option c	Numerical Analysis and Computation
Option d	Algebraic Structures
Option e	Analysis and Differential Equations

Candidates are expected to cover all the topics in Section A, but need not cover more than two out of the five options in Section B. Of the three combinations of two mathematics subjects offered at the 'A' level listed above, Mathematics (Syllabus B) and Further Mathematics are the most popular. The other two combinations have been gradually phased out since the introduction of Mathematics (Syllabus B) and Further Mathematics in 1972.

Section A of the Further Mathematics Papers One and Two comprises mainly the topics found in Mathematics (Syllabus B) with additional items on Algebra, Complex Numbers and Vectors. Section B comprises seven options:

Option a	Mechanics
Option b	Probability and Statistics
Option c	Numerical Analysis and Computation
Option d	Linear Space
Option e	Analysis and Complex Numbers
Option f	Transformation Geometry
Option g	Theory of Numbers

There are two questions on each of the options a to e and one question on each of the options f and g in each paper. Candidates are not allowed to answer more than four questions from Section B, so it is not necessary to cover all the options. Usually, options a, b and e are taught. These options are comparable to the syllabuses of Pure Mathematics, Applied Mathematics and Statistics. Candidates who dislike Mechanics can devote their efforts to Statistics, and vice versa.

The Cambridge Examinations Syndicate has announced that, with effect from 1982, the current Mathematics (Syllabus A), Pure Mathematics, Applied Mathematics and Statistics in the GCE 'A' level examination will be replaced by the new syllabuses: Mathematics (Syllabus A), Further Mathematics (Syllabus A) and Pure Mathematics.

The following changes have been made in the revised Mathematics (Syllabus A).

*Pure Mathematics* 'Coordinate geometry' has been de-emphasized; 'complex numbers' has been introduced.

*Mechanics* 'Friction', 'Hooke's law', 'simple harmonic motion' and 'small oscillation of the simple pendulum' have been removed; 'vectors', 'coefficient of restitution' have been introduced.

*Statistics* 'Descriptive statistics', 'graphical treatment of linear regression and correlation' and 'correlation by ranks' have been re-installed. (These topics were removed in 1976 on revision of the content of Statistics in Syllabus A).

Further Mathematics (Syllabus A) is a new subject which is of a standard equivalent to the existing Further Mathematics (which will be renamed Syllabus B in 1982.) The 'double' mathematics combination of Mathematics (Syllabus A) and Further Mathematics (Syllabus A) will replace the existing combinations of Pure Mathematics and Applied Mathematics/Pure Mathematics and Statistics in 1982. The students may offer Pure Mathematics as a single mathematics subject at the 'A' level. It comprises Paper One of Mathematics (Syllabus A) and Paper One of Further Mathematics (Syllabus A).

The following changes are observed when the new Further Mathematics (Syllabus A) is compared with the existing Pure Mathematics, Applied Mathematics and Statistics Syllabuses.

*Pure Mathematics* 'Pure geometry', 'auxilliary circle and director circle in coordinate geometry' and 'application of integration to moment of inertia' have been removed; 'simple application of de Moivre's theorem for complex numbers' and 'scalar product of vectors and applications' have been introduced.

*Applied Mathematics (Mechanics)* 'Impact and momentum in two dimensions' and 'oblique impact of smooth spheres' have been included.

*Statistics* 'Simple analysis of variance' and 'simple experimental design and survey methods' have been replaced by 'simple queueing problems', 'F-distribution and its applications to tests of hypotheses about variances', 'confidence limits for a population variances' and 'non-parametric tests'.

It is the intention of the Cambridge Examinations Syndicate that Syllabuses A and B be amalgamated in the near future as in the case of the amalgamation of the GCE 'O' Level Mathematics Syllabuses B and C into a single Syllabus D.

Irrespective of the difference in syllabuses, the teaching of mathematics at this level should emphasize the development of ideas and understanding of basic concepts before generalisations. Students should be encouraged to do mathematics from first principles wherever applicable, rather than remembering facts and formulae. The main objective is to help students develop creative and logical thinking, acquire intellectual skills and learn independently.